

Waste powder disposal and recovery

Powder Recycling Wagon

NELCO



Powder Recycling Wagon

Shortening of waste disposal time increases economic efficiency

The Powder Recycling Wagons for easy, clean and quick suction out of waste or residual coating powder. The collecting container is a commercially available big bag which is placed on a pallet for transport. This unit can be used either for refilling or for bagging fresh powder.

On request we supply the appropriate fluidised bed for each container size for later assembly in order to enable a complete extraction of residual powder. The suction device is fixed to the container by means of a quick coupling. The suction process can be controlled either manually or by time switch with different suction running times. Quick couplings provide a fast connection between the powder hose and the air hose. The exhaust filter in the ventilating flap ensures dust-free operation.

The full big bag is removed by a fork-lift and replaced by an empty big bag. The new Powder Pump Wagon can easily be moved and enables successive evacuations at different locations, e.g. within a plant with various powder coating systems.



NELCO

Innovations for Powder Coatings

Powder Recycling Wagon

NELCO

PowderPump RecyclingWagon

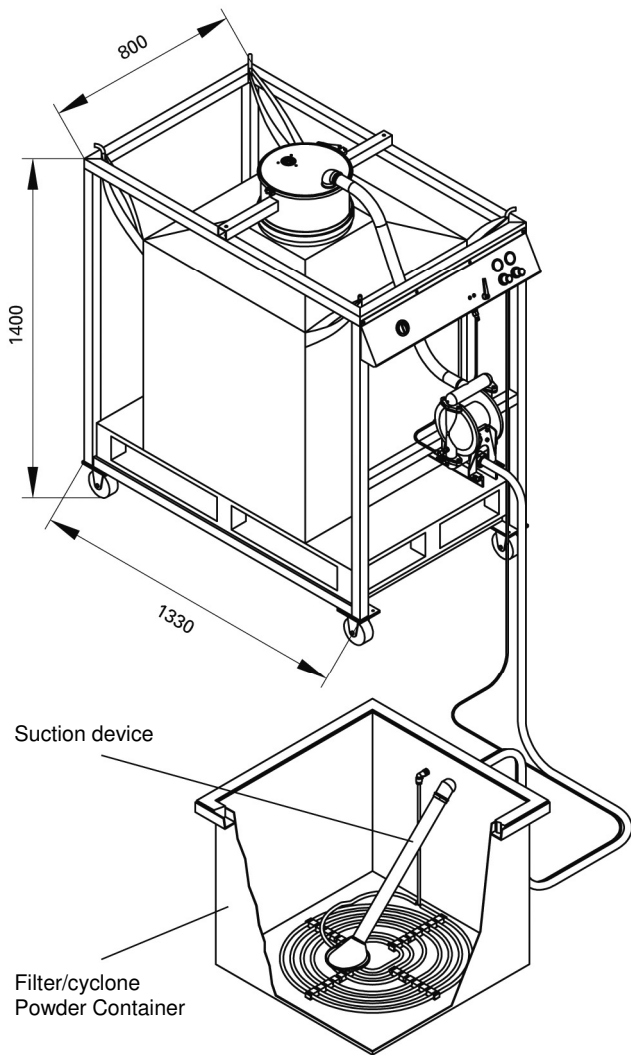

▲ Easy handling

Pumping time, manual operating mode on/off, purging air, fluidisation.



▲ Powder diaphragm pump capacity of pump app. 8 kg/min

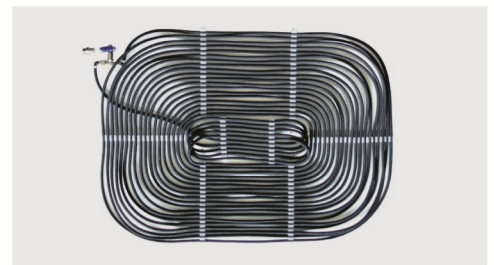

▲ Optional: Fluidised bed

Can be adapted to any powder container floor

Powder Recycling Wagon (Type 18380)

- Wagon with 2 guiding and 2 castor wheels
- Wagon with big bag pick-up including all fixings and connections
- Compressed air standard 1 "diaphragm pump (capacity +/- 8 kg/min)
- 1 time relay for different evacuation running times
- 1 big bag
- 1 exhaust air filter
- 1 set of connection hoses
- 1 suction system suitable for all containers including quick couplings

Technical data

Air capacity: approx. 50 Nm³/h

Current supply: 230 V

Connected load: 0,03 kW

Nelco bvba

Powder Recycling Applications

Hoge olm 5

B-9030 Gent

Tel +32.9.237.05.66

Fax +32.9.270.32.13

Mail info@nelco.be

Web www.nelco.be